

# Turmdrehkran

## T12 EC-B 8

Tower Crane / Grue à tour / Gru a torre  
Grúa torre / Guindaste de torre

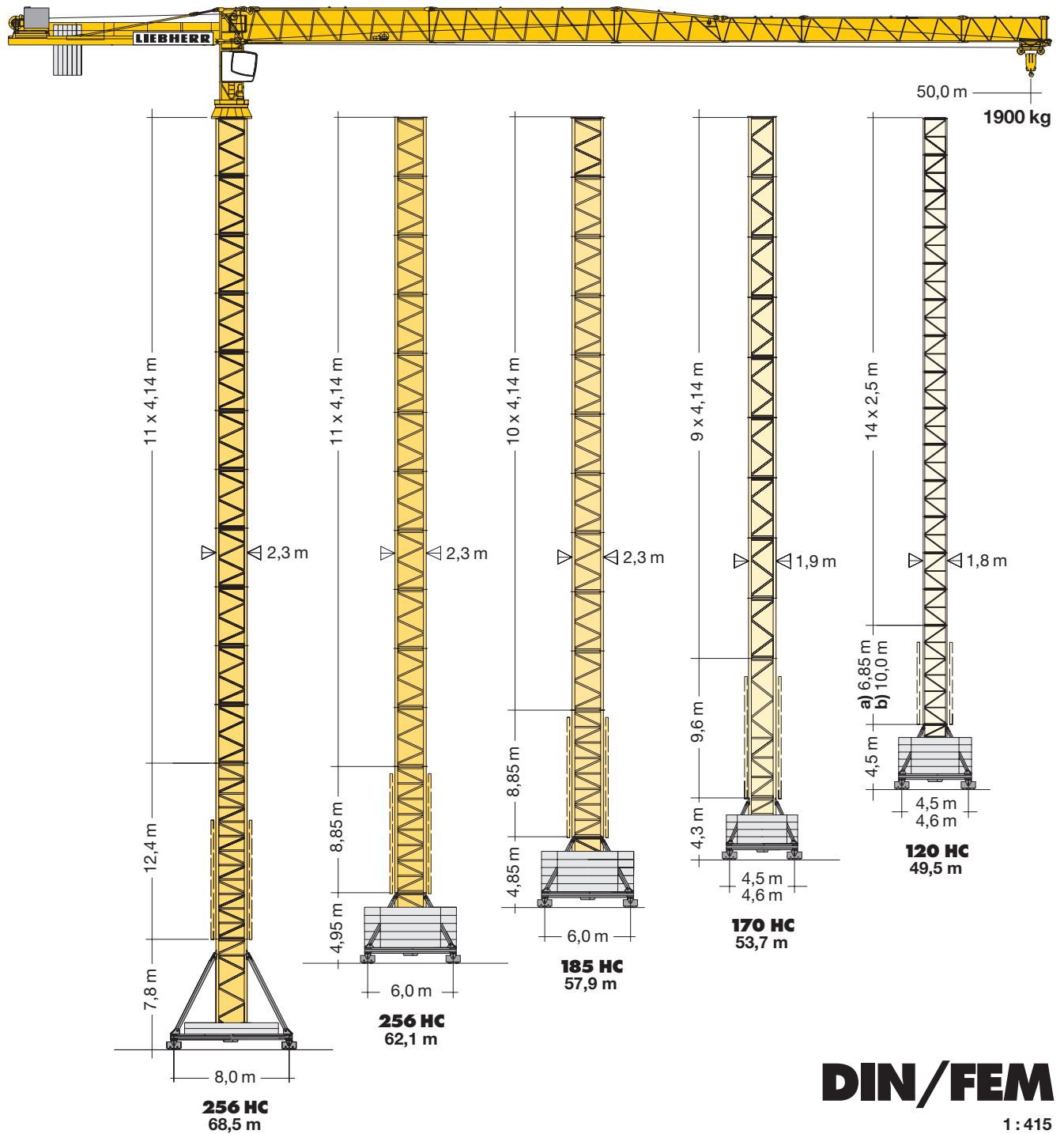

**DIN/FEM**

1:415

# LIEBHERR

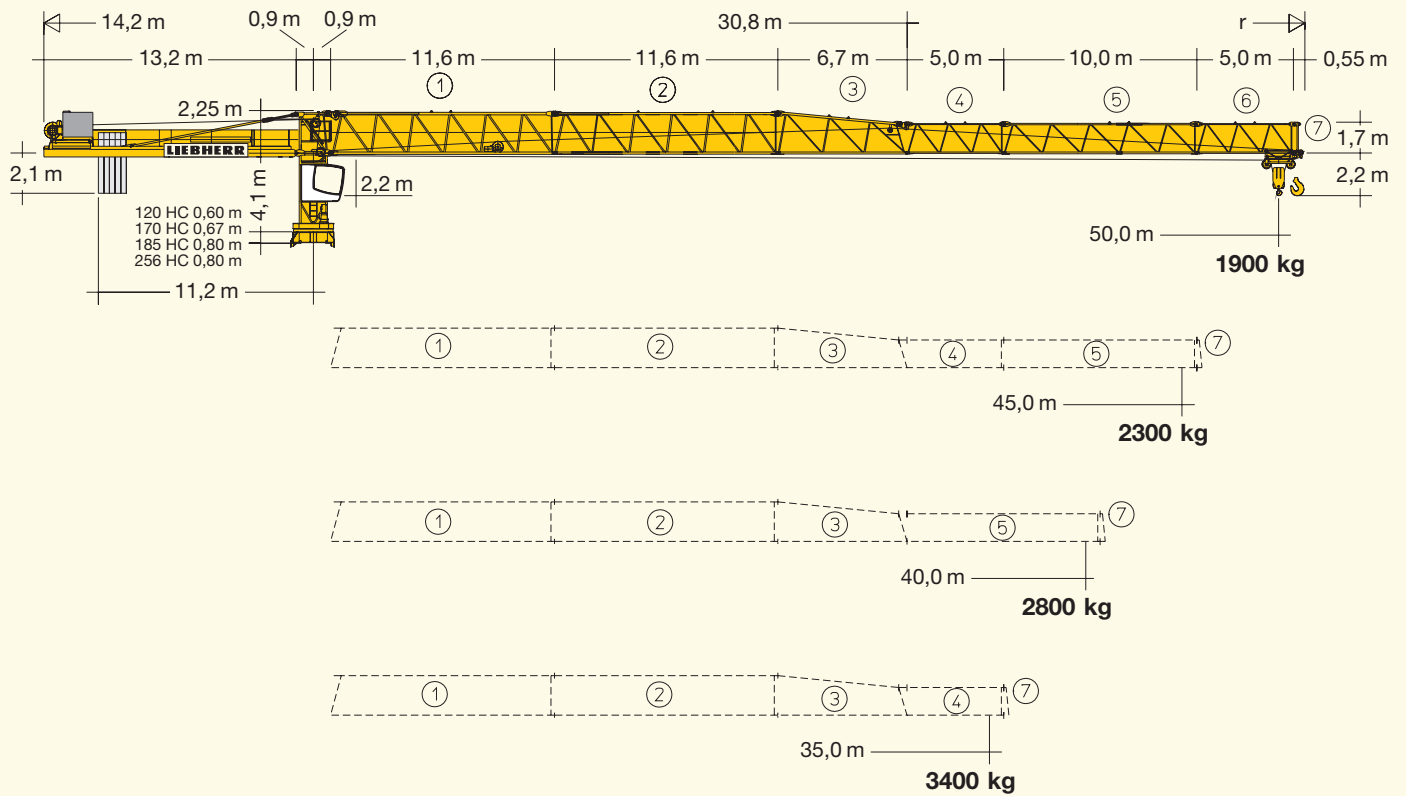

## Hubhöhe

Hoisting height / Hauteur sous crochet / Altezza di sollevamento / Altura bajo gancho / Altura de montagem

		120 HC														
15	-	-	-	-	47,1*	-	-	-	-	-	-	-	-	-	-	-
14	48,9*	-	48,4*	-	44,6*	-	-	-	-	-	-	47,3*	-	-	46,8*	-
13	46,4	49,5*	45,9	49,0*	42,1	45,2*	43,6*	-	43,4*	-	-	44,8	-	-	44,3	-
12	43,9	47,0*	42,4	46,5	39,6	42,7*	41,1*	44,2*	40,9*	44,0*	-	42,3	-	45,4*	41,8	44,9*
11	41,4	44,5	40,9	44,0	37,1	40,2	38,6	41,7*	38,4	41,5*	-	39,8	42,9	-	39,3	42,4
10	38,9	42,0	38,4	41,5	34,6	37,7	36,1	39,2	35,9	39,0	-	37,3	40,4	-	36,8	39,9
9	36,4	39,5	35,9	39,0	32,1	35,2	33,6	36,7	33,4	36,5	-	34,8	37,9	-	34,3	37,4
8	33,9	37,0	33,4	36,5	29,6	32,7	31,1	34,2	30,9	34,0	-	32,3	35,4	-	31,8	34,9
7	31,4	34,5	30,9	34,0	27,1	30,2	28,6	31,7	28,4	31,5	-	29,8	32,9	-	29,3	32,4
6	28,9	32,0	28,4	31,5	24,6	27,7	26,1	29,2	25,9	29,0	-	27,3	30,4	-	26,8	29,9
5	26,4	29,5	25,9	29,0	22,1	25,2	23,6	26,7	23,4	26,5	-	24,8	27,9	-	24,3	27,4
4	23,9	27,0	22,4	26,5	19,6	22,7	21,1	24,2	20,9	24,0	-	22,3	25,4	-	21,8	24,9
3	21,4	24,5	20,9	24,0	17,1	20,2	18,6	21,7	18,4	21,5	-	19,8	22,9	-	19,3	22,4
2	18,9	22,0	18,4	21,5	14,6	17,7	16,1	19,2	15,9	19,0	-	17,3	20,4	-	16,8	19,9
1	16,4	19,5	15,9	19,0	12,1	15,2	13,6	16,7	13,4	16,7	-	14,8	17,9	-	14,3	17,4
0	a) 13,9 b) 17,0		a) 13,4 b) 16,5		a) 9,6 b) 12,7		a) 11,1 b) 14,2		a) 10,9 b) 14,0			a) 12,3 b) 15,4			a) 11,8 b) 14,9	
	m		m		m		m		m			m			m	

\* Weitere Hubhöhen sowie Klettern im Gebäude auf Anfrage. / Further hoist heights and climbing in the building on request.  
 Hauteurs sous crochet plus élevées et hissage dans le bâtiment sur demande. / Altre altezze di sollevamento come pure varianti di gru allungabili: su richiesta. / Para alturas bajo gancho superiores y trepado en el interior del edificio, consultar. / Outras alturas de elevação e subida no edifício: conforme ao pedido.

# Ausladung und Tragfähigkeit

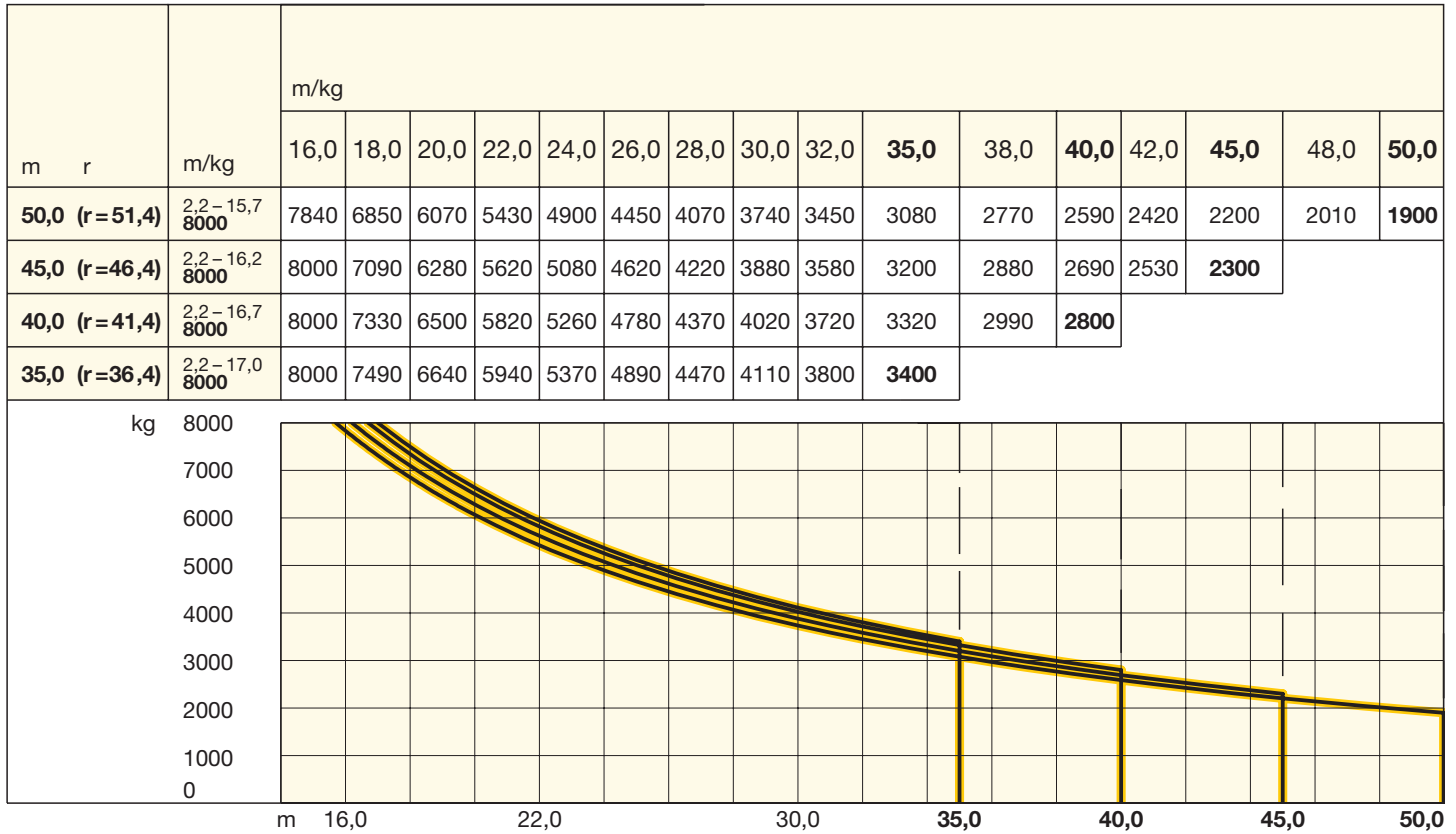

Radius and capacity / Portée et charge / Sbraccio e portata / Alcances y cargas / Alcance e capacidade de carga



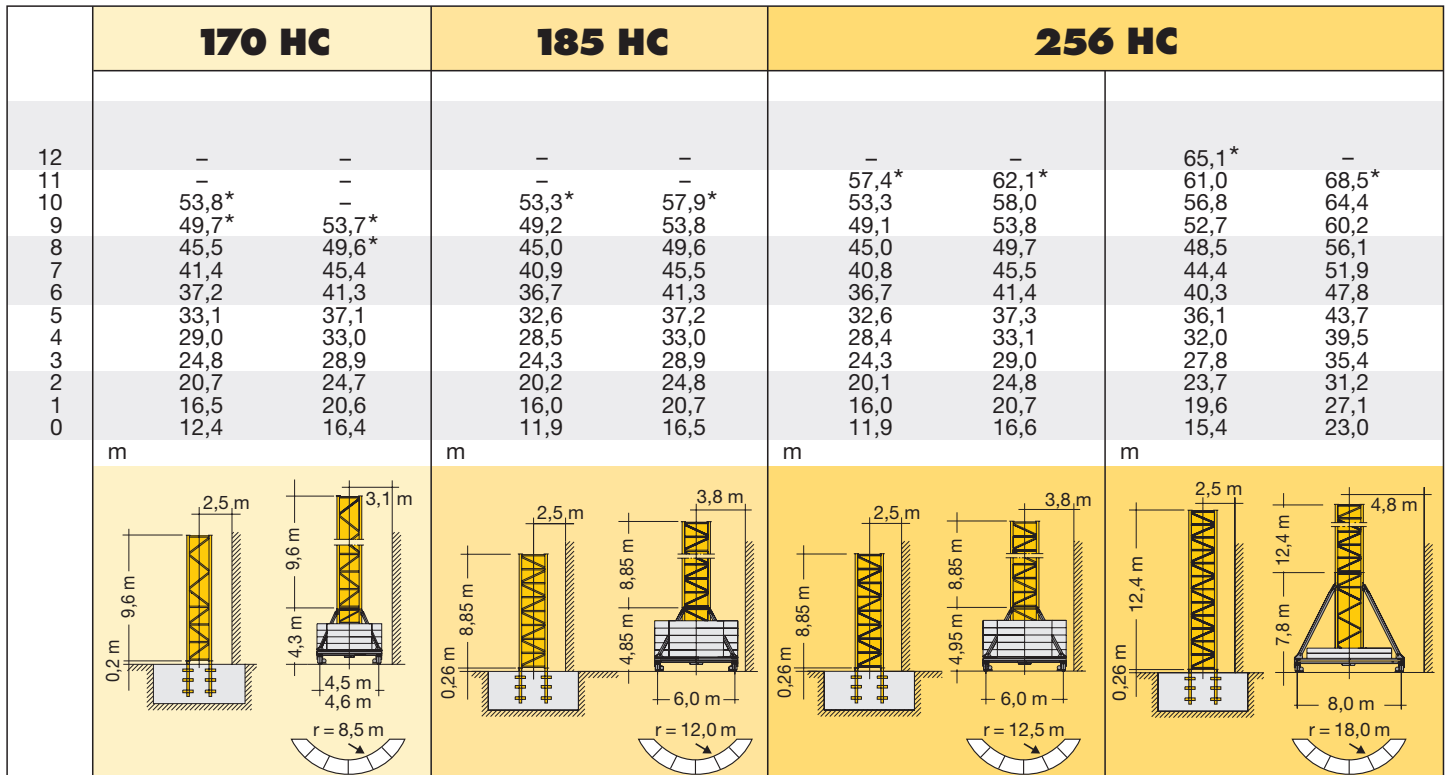

# Antriebe

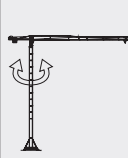
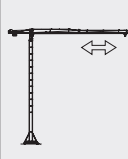
Driving units / Mécanismes d'entraînement / Azionamenti / Mecanismos / Mecanismos



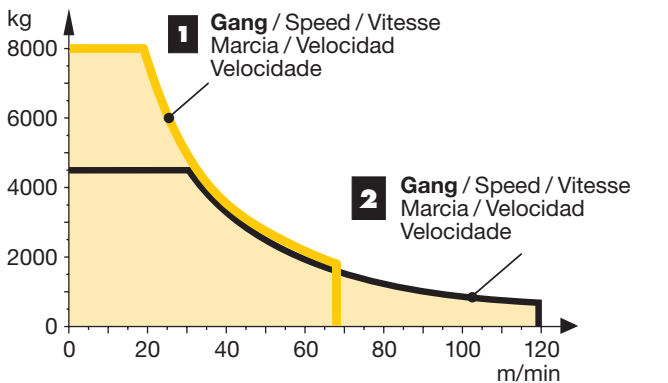



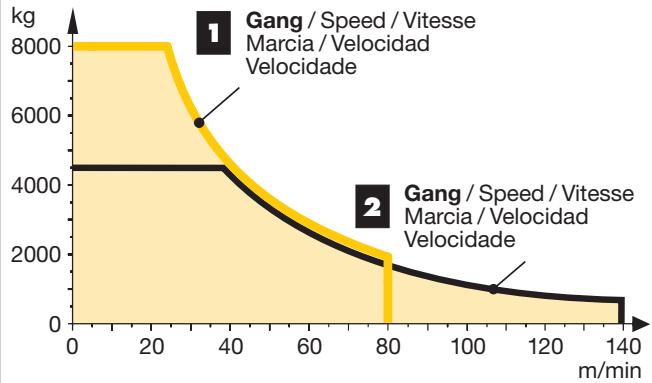









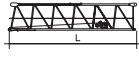

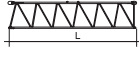

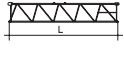









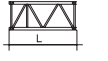

	U/min 0 ↔ 0,8 sl./min tr./min	1 x 6,3 kW
	0 ↔ 100,0 m/min	5,5 kW FU
	25,0 m/min	2 x 3,0 kW 120 HC (132 HC) 2 x 7,5 kW 256 HC (290 HC) 2 x 5,5 kW (185 HC, 170 HC)
	<b>kVA</b>	30 kW FU 37 kW FU 45,0 50,0

	↔ <b>stufenlos</b> / stepless / régl. continu regl. progressiva / sin escalones / sem degraus kg m/min												
30,0 kW FU WIW 240 VZ 402  4 <b>Lagen</b> Layers Couches Strati Camadas Capas  116,0 m LS-Trommel	<table border="1"> <tr> <td><b>1</b></td> <td>8000</td> <td>0 ↔ 19</td> </tr> <tr> <td></td> <td>1800</td> <td>0 ↔ 68</td> </tr> <tr> <td><b>2</b></td> <td>4600</td> <td>0 ↔ 32</td> </tr> <tr> <td></td> <td>800</td> <td>0 ↔ 120</td> </tr> </table>	<b>1</b>	8000	0 ↔ 19		1800	0 ↔ 68	<b>2</b>	4600	0 ↔ 32		800	0 ↔ 120
<b>1</b>	8000	0 ↔ 19											
	1800	0 ↔ 68											
<b>2</b>	4600	0 ↔ 32											
	800	0 ↔ 120											
 <p><b>1</b> Gang / Speed / Vitesse Marcia / Velocidad Velocidade</p> <p><b>2</b> Gang / Speed / Vitesse Marcia / Velocidad Velocidade</p>													





	↔ <b>stufenlos</b> / stepless / régl. continu regl. progressiva / sin escalones / sem degraus kg m/min												
37,0 kW FU WIW 250 VZ 401  6 <b>Lagen</b> Layers Couches Strati Camadas Capas  186,0 m LS-Trommel	<table border="1"> <tr> <td><b>1</b></td> <td>8000</td> <td>0 ↔ 24</td> </tr> <tr> <td></td> <td>1800</td> <td>0 ↔ 80</td> </tr> <tr> <td><b>2</b></td> <td>4600</td> <td>0 ↔ 40</td> </tr> <tr> <td></td> <td>800</td> <td>0 ↔ 140</td> </tr> </table>	<b>1</b>	8000	0 ↔ 24		1800	0 ↔ 80	<b>2</b>	4600	0 ↔ 40		800	0 ↔ 140
<b>1</b>	8000	0 ↔ 24											
	1800	0 ↔ 80											
<b>2</b>	4600	0 ↔ 40											
	800	0 ↔ 140											
 <p><b>1</b> Gang / Speed / Vitesse Marcia / Velocidad Velocidade</p> <p><b>2</b> Gang / Speed / Vitesse Marcia / Velocidad Velocidade</p>													

**Elmag-Hubwerke: siehe Broschüre „Zusätzliche Hubwerksvarianten“** / Hoist gears: see brochure „Additional hoist gear variants“  
 Mécanismes de levage: voir brochure „Variantes supplémentaires du mécanisme de levage“ / Argani ad innesto elettromagnetico: vedere  
 prospetto „argani alternativi“ / Mecanismos de elevación de Elmag: Ver folleto „Mecanismos de elevación adicionales“ / Mecanismos de  
 elevacao de ELMAG: Ver Folheto „Mecanismos de elevação adicionais“

Montagegewichte: siehe Betriebsanleitung. / Erection weights: see instruction manual. / Poids de montage: voir manuel de service.  
Pesi di montaggio: vedasi le istruzioni sull'uso. / Pesos de montagem: vejã-se as instruções p. uso. / Peso para el montaje: según manual.

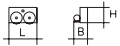
<b>Kranoberteil</b>		<b>Upper part of crane / Partie supérieure de grue / Parte superiore della gru</b>		<b>L (m)</b>	<b>B (m)</b>	<b>H (m)</b>	<b>kg*</b>		
Pos. Item Ref	Anz. Qty. Qta. Cant.								
1	1	<b>Drehbühne kpl.</b> / Slewing platform cpl. Ensemble mât cabine cpl. / Piattaforma girevole compl. / Conjunto plataforma de giro / Plataforma giratória compl.			120 HC (132 HC) 170 HC 185 HC (200 HC) 256 HC (290 HC)	7,14 7,58 7,58	2,30 2,74 2,74	2,50 2,66 2,66	8300 8950 9000 9000
2	1	<b>Gegenausleger</b> / Counter-jib Contre-flèche / Controbraccio Contrapluma / Contra-lança				13,23	2,42	0,91	3940
3	1	<b>Ausleger-Anlenkstück</b> / Jib heel section Pied de flèche / Settore articolato di braccio / Base articulada de lança Pluma tramo primero				11,87	1,70	2,37	① 2870
4	1	<b>Ausleger-Zwischenstück</b> / Intermediate jib section / Élément intermédiaire de flèche Spezzone di braccio / Peça suplementar da lança / Tramo intermedio pluma				11,88	1,50	2,25	② 1740
5	1	<b>Ausleger-Zwischenstück</b> / Intermediate jib section / Élément intermédiaire de flèche Spezzone di braccio / Peça suplementar da lança / Tramo intermedio pluma				10,31	1,50	1,68	③ 730
6	1	<b>Ausleger-Zwischenstück</b> / Intermediate jib section / Élément intermédiaire de flèche Spezzone di braccio / Peça suplementar da lança / Tramo intermedio pluma				6,90	1,50	2,25	④ 810
7	2	<b>Ausleger-Zwischenstück</b> / Intermediate jib section / Élément intermédiaire de flèche Spezzone di braccio / Peça suplementar da lança / Tramo intermedio pluma				5,31	1,50	1,68	⑤ 530 ⑥ 320
8	1	<b>Ausleger-Kopfstück</b> / Jib head Pointe de flèche / Punta freccia Cabeça de lança / Tramo punta de pluma				0,62	1,73	1,88	⑦ 150
9	1	<b>Laufkatze und Lasthaken</b> / Trolley and hook Chariot de distribution et crochet / Carrello con gancio / Carrito y gancho / Carro de ponte e gancho				1,82	1,69	1,44	860
10	1	<b>Hubwerkseinheit</b> / Hoist gear unit / Treuil de levage / Gruppo meccanismo sollevamento Mecanismo de elevación / Grupo de mecanismo elevatório			WIW 260 MW 406	2,70	2,30	1,70	2750
11	1	<b>Gegenausleger mit Hubwerkseinheit 45 kW</b> Counter-jib with hoist gear unit / Contre-flèche avec treuil de levage / Controbraccio con gruppo meccanismo sollevamento Contrapluma con mecanismo de elevación Contra-lança com grupo de mecanismo elevatório				13,23	2,42	2,44	8300
<b>Turm</b>		<b>Tower / Mât / Torre</b>							
12	14 9 10 11	<b>Turmstück</b> / Tower section Element de mât / Elemento di torre Torre / Torre			120 HC (132 HC) 170 HC 185 HC (200 HC) 256 HC (290 HC)	2,50 4,14 4,14 4,14	1,80 1,90 2,30 2,30	1,80 1,90 2,30 2,30	1050 1850 2050 2260
13	7 3	<b>Turmstück lang</b> / Long tower section Élément de mât long / Elemento di torre, lungo Tramo de torre largo / Peça de torre, comprida			120 HC (132 HC) 120 HC (132 HC) 120 HC (132 HC)	5,0 10,0 12,5	1,80 1,80 1,80	1,80 1,80 1,80	1960 3400 4200
14	1	<b>Grundturmstück</b> / Base tower section Mât de base / Elemento di torre base Tramo torre base / Peça de base de torre			120 HC (132 HC) 120 HC (132 HC) 170 HC 185 HC (200 HC) 256 HC (290 HC)	6,85 10,00 9,60 8,85 8,85 (12,42)	1,80 1,80 1,90 2,30 2,30 (2,30)	1,80 1,80 1,90 2,30 2,30 (2,30)	2560 3420 4350 4100 4580 (7700)
<b>Klettereinrichtung</b>		<b>Climbing equipment / Equipement de télescopage / Attrezzatura per allungamento della gru</b>							
15	1	<b>Führungsstück kpl.</b> / Guide section cpl. Cage télescopique cpl. / Gabbia de sopraelevazione compl. / Peça de guia compl. / Torre de montagem completa			120 HC (132 HC) 120 HC (132 HC) 170 HC 185 HC (200 HC) 256 HC (290 HC)	6,45 9,60 9,04 8,39 8,39	2,10 2,10 2,31 2,68 2,68	2,42 2,42 2,28 2,58 (3,04) 2,58 (3,04)	2660 4410 4750 5100 5100
16	1	<b>Hydraulikanlage, Stütz- und Klettertraverse</b> / Hydraulic unit, supporting and climbing cross members / Système hydraulique avec traverses d'appui et de télescopage / Sistema idraulico, traversa di appoggio e allungamento gru / Instalação hidráulica, travessa de apoio e subida Sistema hidráulico con travesa de apoyo y trepado			120 HC (132 HC) 170 HC 185 HC (200 HC) 256 HC (290 HC)	2,87 2,00 2,30 2,30	2,12 1,10 1,25 1,25	1,06 1,00 1,00 1,00	1050 1100 1150 1150

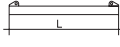
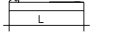
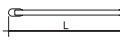
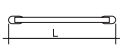
Pos. Anz.  
Item Qty.  
Rep. Qte.  
Voce Qta.  
Pos. Cant.  
Ref. Cant.

				L (m)	B (m)	H (m)	kg*	
<b>Unterwagen</b> Undercarriage / Châssis / Carro della gru Carro con mástil / Carro de guindaste								
17	2	<b>Fahrschemel mit Antrieb</b> / Rail bogie with drive / Bogie moteur / Telaio con gruppo propulsore / Quadro sem grupo de propulsão Caja rodillo motriz		120 HC (132 HC) 170 HC 185 HC (200 HC) 256 HC (290 HC)	1,38 1,46 1,46 1,63 (1,46)	0,88 0,84 0,84 0,92 (0,84)	0,87 0,87 0,87 0,95 (0,87)	900 920 920 1690 (920)
18	2	<b>Fahrschemel ohne Antrieb</b> / Rail bogie without drive / Bogie fou / Telaio senza gruppo propulsore / Quadro com grupo de propulsão Caja rodillo conducido		120 HC (132 HC) 170 HC 185 HC (200 HC) 256 HC (290 HC)	1,17 1,15 1,15 1,37 (1,15)	0,60 0,60 0,60 0,62 (0,60)	0,87 0,87 0,87 0,95 (0,87)	860 880 880 1340 (880)
19	1	<b>Tragholm lang</b> / Long support arm Longeron long / Longherone lungo Braço largo soporte / Travessa comprida		120 HC (132 HC) 170 HC 185 HC (200 HC) 256 HC (290 HC)	7,12 7,15 9,10 9,10 (11,95)	0,78 0,80 0,82 0,80 (0,82)	0,65 0,70 0,74 0,80 (0,80)	950 1070 1350 1650 (2200)
20	2	<b>Tragholm kurz</b> / Short support arm Longeron court / Longherone corto Braço corto soporte / Travessa curta		120 HC (132 HC) 170 HC 185 HC (200 HC) 256 HC (290 HC)	3,45 3,45 4,41 4,45 (5,58)	0,56 0,60 0,62 0,77 (0,65)	0,55 0,70 0,71 0,77 (0,77)	408 500 615 800 (1035)
21	2 + 2	<b>Randträger</b> / Border support Traverse / Supporti base Traviesa / Apoio de bordo		120 HC (132 HC) 170 HC 185 HC (200 HC) 256 HC (290 HC)	4,02 4,08 - 4,30 5,48 - 5,46 5,46 - 5,40 (7,52 - 7,46)	0,35 0,16 - 0,33 0,11 - 0,17 0,11 - 0,18 (0,10 - 0,17)	0,12 0,11 - 0,14 0,16 - 0,38 0,16 - 0,38 (0,10 - 0,38)	95 80 - 200 118 - 454 175 - 525 (366 - 912)
22	4	<b>Stützhalm</b> / Support strut Hauban de châssis / Correnti di appoggio Tirante vertical / Travessa de apoio		120 HC (132 HC) 170 HC 185 HC (200 HC) 256 HC (290 HC)	3,78 3,53 4,23 4,14 (6,55)	0,15 0,25 0,17 0,18 (0,22)	0,22 0,17 0,25 0,25 (0,25)	200 240 275 320 (600)
23	1	<b>Unterwagen-Turmstück</b> / Undercarriage tower section / Mât de châssis / Elemento di torre del carro / Tramo de carro / Peça de torre do chassis		120 HC (132 HC) 170 HC 185 HC (200 HC) 256 HC (290 HC)	3,50 3,30 3,73 3,73 (6,70)	2,06 2,15 2,52 2,62 (2,53)	2,06 2,15 2,52 2,62 (2,53)	1320 2000 1950 2550 (3800)
24	1	<b>Stapel Aufstiege und Podeste</b> / Bundle of ladders and platforms Faisceau d'échelles et de plates-formes / Serie di scale e rampe Paquete de escaleras y plataformas / Escadas e patamares		120 HC (132 HC)	3,50	1,20	1,00	1000
25	1	<b>Kiste mit Kleinteilen</b> / Crate with small parts Caisse contenant des accessoires / Cassa con accessori Caja con accesorios / Caixa de acessórios			2,00	1,00	1,00	2000

( ) **Angaben in Klammern gelten für 8 m-Unterwagen.** / The data in brackets are valid for an undercarriage of 8 m. / Les données techniques indiquées entre parenthèses sont valables pour un châssis de 8 m. / Caratteristiche in (...) valgono per carro di 8 m. / Los datos entre paréntesis son válidos para carro de 8 m. / Características em (...) válidas pelo chassis de 8 m.

\* **Einzelgewichte.** / Single weights. / Poids individuels. / Pesì di componenti. / Pesos de peças componentes. / Pesos unitarios.

**Konstruktionsänderungen vorbehalten!**

Subject to alterations! / Sous réserves de modifications!  
Si fa riserva di modifiche! / Salvo modificação da construação!  
¡Sujeto a modificaciones!

**Sämtliche Angaben erfolgen ohne Gewähr.** / This information is supplied without liability.

Ces renseignements sont sans garantie. / Le indicazioni contenute si intendono salvo errori ed omissioni.  
Declinamos toda responsabilidad derivada de la información proporcionada. / Declinamos qualquer  
responsabilidade quanto à informação fornecida.