

Gru idraulica
di qualità
100% Italiana

OMV 260

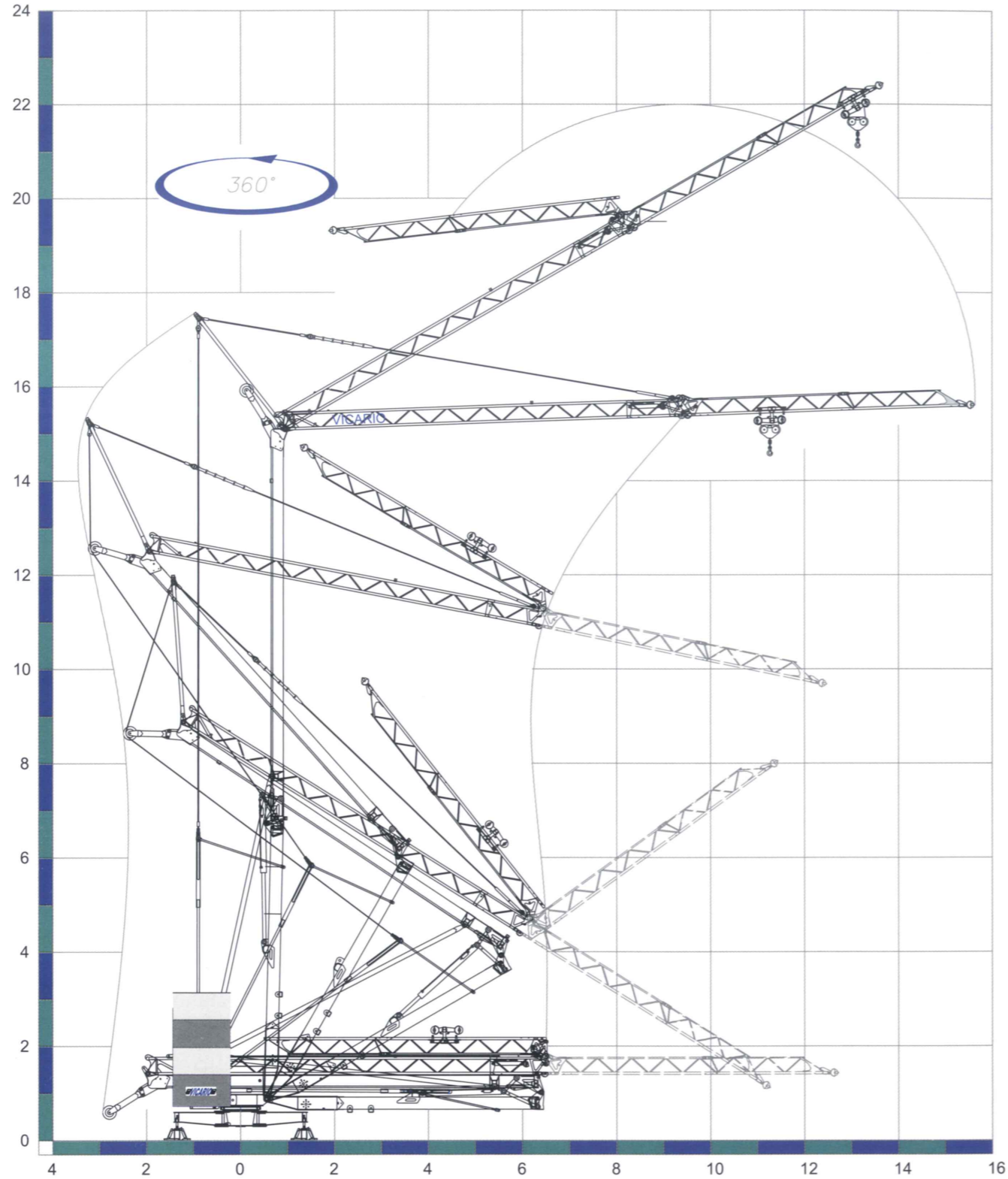

Sequenza di montaggio su 360°. Aufstellvorgang über 360°. Déroulement de montage sur 360°. Erection procedure on 360°. Montaje sobre 360°.

Ufficio Tecnico OMV Vicario SpA - 10/06

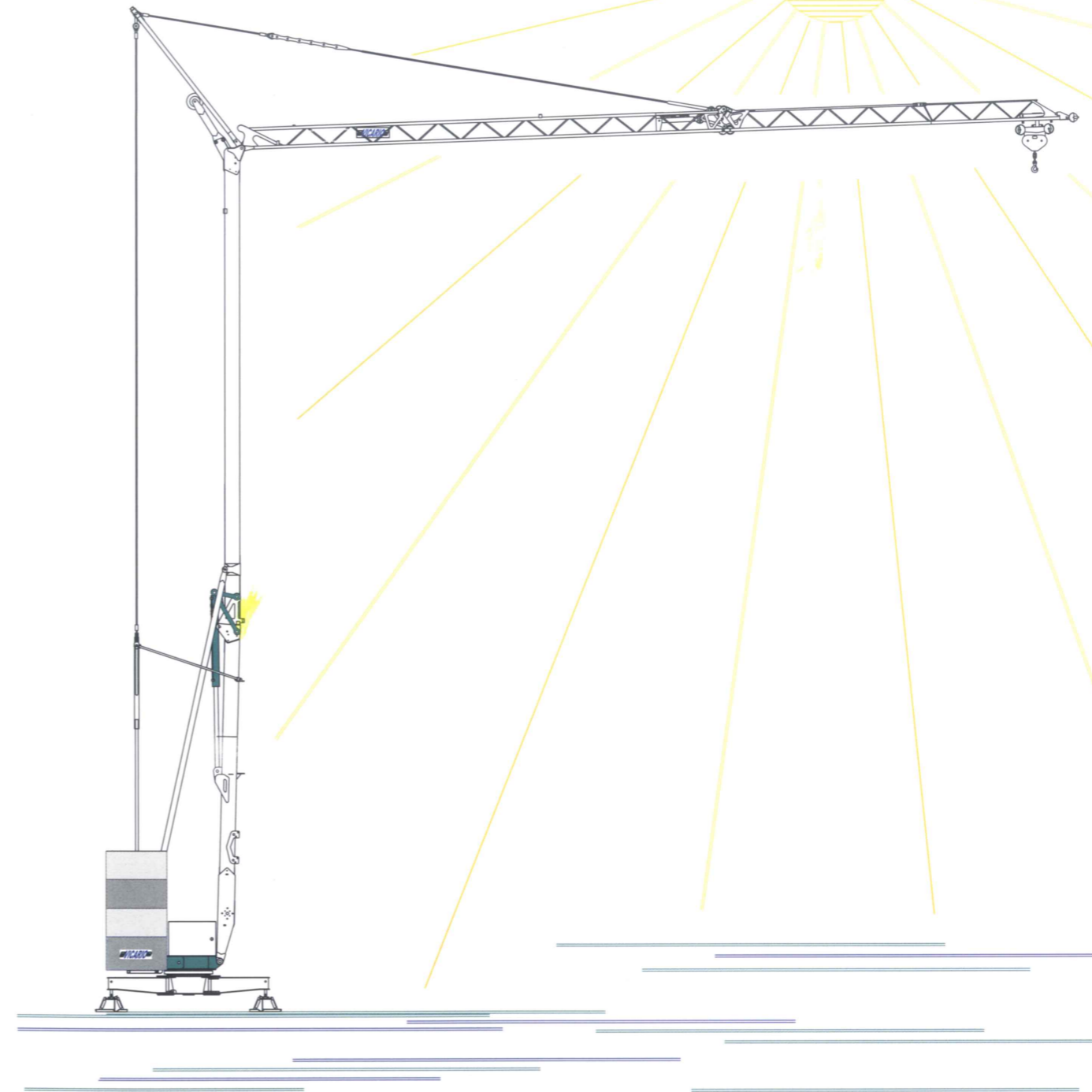

CRANES
and
TOOLS **VICARIO**
Officine Meccaniche Vicario S.p.a.

Via Piola, 4

28013 Gattico (NO) ITALIA

Tel. 0322 846690 Fax 0322 846692

Internet: www.vicariogru.com E-Mail: omv@vicariogru.com

Agente di zona:



una novità delle Officine Meccaniche
Ein neuer VICARIO Kran
A new crane from VICARIO Industries

Une nouvelle grue de VICARIO
Una nueva grua de VICARIO

VICARIO

OMV 260

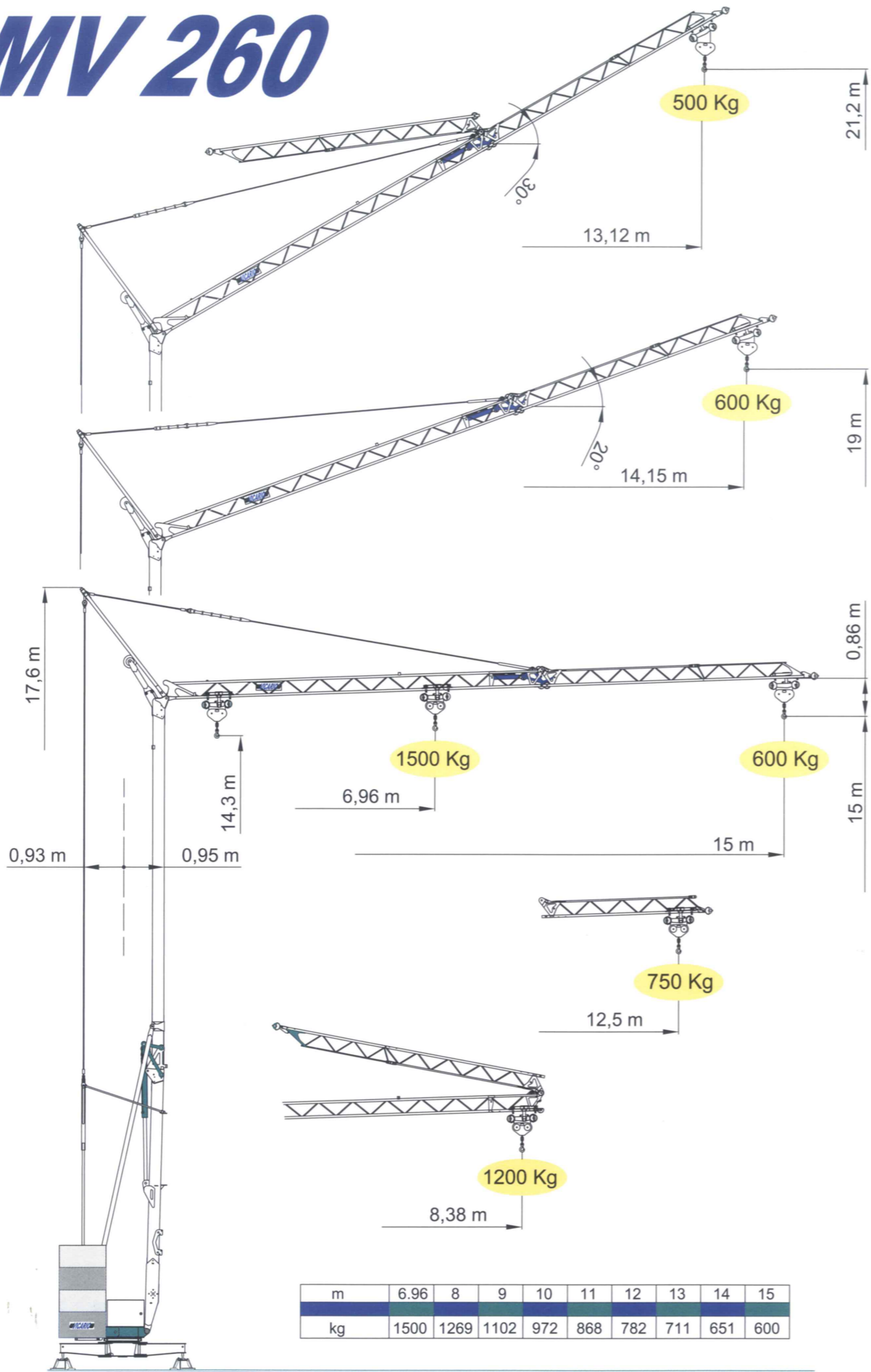

DOTAZIONE DI SERIE

Sollevamento, rotazione e carrello a tre velocità con inverter, zincatura della struttura e dei tiranti, contrappeso, braccio impennabile, carrello rampante con motore e finecorsa alla base della torre, funzionamento con braccio ripiegato, comando a pulsantiera via cavo, carter di protezione per ralla e meccanismi, predisposizione per autozavorramento e radiocomando, armadio elettrico in acciaio inox, documentazione a norme CEE.

STANDARD FEATURES

3-speed lifting, rotation and trolley with inverter control, galvanised structure, counterweight, pull-up jib, translation trolley with motor and limit switch at base of gantry, operation with folden jib, cable-operated pushbutton remote control, guard for slewing ring and mechanisms, designed to allow installation of self-ballasting device and radio control, stainless steel electrical cabinet, documentation in accordance with EU standards.

EQUIPEMENT DE SERIE

Levage, chariot et rotation à trois vitesses à contrôle électronique, galvanisation de la structure et des tirants, contrepoids, flèche relevable, moteur de chariot et fin de course à la base de la tour, fonctionnement bras replié, commande par câble, carter de protection pour la couronne et les mécanismes, predisposition pour autoestage et commande radio, armoire électrique en acier inox, documentation conforme aux normes CEE.

SERIENAUSSTATTUNG

Heben, Laufkatze und Rotation mit drei Geschwindigkeiten. Strukturverzinkung, Gegengewicht, hochklappbarer Arm, aufsteigender Wagen mit Motor und Anschlag an der Basis des Turms. Funktionieren mit eingeklapptem Arm. Steuerung mit Druckknopftaste via Kabel. Schutzvorrichtungen für Drehverbindungen und Mechanismen. Vorbereitung für Selbstballasteinahme und Funksteuerung, elektrischer Schrank aus rostfreiem Stahl. Dokumentation gemäß EC Vorschriften.

DOTACION DE SERIE

Levantamiento, carro y rotación a tres velocidades con control electrónico, galvanización de la estructura, contrapeso, brazo empinable, carro rampante con motor y fin de carrera en la base de la torre, funcionamiento con brazo replgado, funcionamiento por pulsadores via cable, carter de protección para corona de giro y mecanismos, predisposición para autocontrapeso y radioccontrol, armario eléctrico de acero inox, documentación según normas CEE.

	230V (±10%) 50 Hz	3kVA	
	m/l' kg kW	6 ↑ 6 ↓ 12 ↑ 12 ↓ 24 ↑ 30 ↓ 1500 1500 600	
	m/l' kW	11.8 18.9 35.4 (26) 1.85 (inverter)	
	m/l' kW	0.23 0.58 1.15 1.1 (inverter)	
	min kW	4 1.5	
	4350 Kg	3700 Kg + 3800 Kg	3000 Kg + 4500 Kg

